

Technical specifications

Three-phase transformer operated meters
EWGE32x and EWGE34x

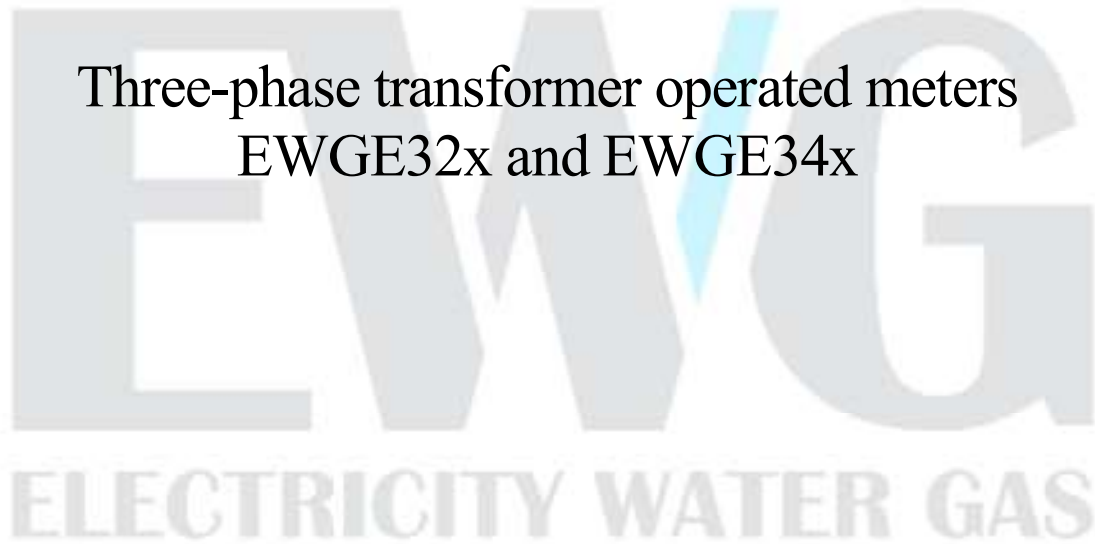

Table of Contents

1. Meters introduction.....	5
1.1. Metrological characteristics of the meters.....	5
1.1.1. Accuracy class of the meters.....	5
1.1.2. Metrological parameters of EWGE32x and EWGE34x meters family.....	6
1.1.3. Standards and references	9
2. Design of the meter	10
2.1. Meter housing (construction)	10
2.1.1. Front and bottom view.....	10
2.1.2. Overall meter housing dimensions.....	11
2.1.3. Terminal block.....	11
2.2. Meter labels	13
2.2.1. Name plate.....	13
2.2.2. OBIS code plate	14
2.2.3. Connection diagram	15
2.3. Additional module case – communication modules.....	16
2.4. Sealing.....	16
3. Electronic boards – PCB's.....	18
3.1. Upper electronic board	18
3.1.1. Signal input pins	19
3.1.2. Analogue front end (AFE).....	19
3.1.3. Digital computation engine (CE)	19
3.1.4. 80515 microprocessor core (MPU).....	20
3.1.5. ARM microprocessor (core M0).....	20
3.1.6. Optical test output.....	20
3.1.7. Meter buttons.....	21
3.2. Lower electronic board	21
3.2.1. Power supply.....	21
3.2.2. Electrical test output.....	21
3.2.3. Auxiliary relay.....	22
3.3. Meter communication ports.....	22
3.3.1. Optical port	22
3.3.2. Electrical communication port.....	22
4. LCD - data display procedure	23

4.1.	Display.....	23
4.1.1.	Alphanumeric fields (data value and OBIS code field).....	23
4.1.2.	Physical units field.....	23
4.1.3.	Power flow direction cursors.....	23
4.1.4.	Phase voltage presence indicator.....	24
4.1.5.	Tariff and error cursors.....	24
4.2.	Data Display Procedure.....	24
4.2.1.	Automatic mode.....	26
4.2.2.	Manual mode.....	28
4.2.3.	Test mode.....	31
5.	Additional meter functions.....	33
5.1.	Profiles of measured and registered values.....	33
5.1.1.	Billing profile.....	33
5.1.2.	Load profile with recording period 1.....	34
5.1.3.	Load profile with recording period 2.....	34
5.1.4.	Load profile with recording period 3.....	34
5.1.5.	Load profile during test.....	34
5.2.	Logs.....	34
5.2.1.	Standard Event Log.....	35
5.2.2.	Power quality log (sag and swell).....	35
5.2.3.	Integrity violation log.....	35
5.2.4.	Power failure log.....	36
6.	Tariff control.....	37
7.	Software update.....	38
8.	Data transfer security.....	39
9.	Meter marking.....	40
10.	Packaging and Storage.....	41

<i>Document: version 2.5</i>	<i>Name</i>	<i>Date</i>
<i>Written by</i>	Saša Aleksandrov	14.06.2023.
<i>Controlled by</i>	Žarko Ranđelović	14.06.2023.
<i>Approved by</i>	Nenad Nikolić	15.06.2023.

<i>Document: version 2.5</i>	<i>List of changes</i>	<i>Datum</i>
	Electrical test output – SO: optional	26.10.2019.
	Meter type label changed to EWG E 3xx Nx AxRx C0 S	22.05.2020.
	Type approval extension	14.06.2023.
	New ARM processor with G0 mark	14.06.2023.
	Meter type label changed to EWG E 31x Nx AxRx C0 S P	14.06.2023.



1. Meters introduction

EWGE32x family consist of the three-phase electronic (static) meters for connection in three-phase four wire low voltage grid over current transformers.

EWGE34x family consist of the three-phase electronic (static) meters for connection in three-phase four wire or three-phase three wire (Aaron connection) medium/high voltage grid over current and voltage transformers.

The meters are designed for measuring of the active and reactive energy consumption and maximum power demand for up to four tariffs, instantaneous (RMS) values of the active power, current and voltage. The meters have build-in real time clock (RTC) and tariff management calendar.

1.1. Metrological characteristics of the meters

Measuring and technical characteristics of the meter comply with EN 50470 – 1 and EN 50470-3 European standards for static active energy meters classes B and C (IEC 62052-11 and IEC 62053-21 international standards for electronic active energy meters, classes 1 and 0.5S) and international standard IEC 62053-22 for class 0.2S as well as for reactive energy meters classes 2 and 3 in compliance with IEC 62053-23.

1.1.1. Accuracy class of the meters

Type of meter	Number of measurement systems	Grid	Relevant standards	Accuracy class
EWGE32x	3	3 phase - 4 wire	Active energy EN50470 – 1 and EN50470 – 3	B and C
			Active energy IEC62053-21 and IEC62053-22	1 and 0.5S
			Reactive energy IEC62053-23	2 and 3
E34xxx	3	3 phase - 4 wire	Active energy EN50470 – 1 and EN50470 – 3	C
			Active energy IEC62053-21 and IEC62053-22	0.5S
			Reactive energy IEC62053-23	2 and 3
EWGE34x	2	3 phase - 3 wire	Active energy EN50470 – 1 and EN50470 – 3	C
			Active energy IEC62053-21 and IEC62053-22	0.5S
			Reactive energy IEC62053-23	2 and 3

1.1.2. Metrological parameters of EWGE32x and EWGE34x meters family

Meter family		EWGE32x	EWGE34x
Nominal voltage		3x230/400 V	3x57.7/100 V
Voltage range		$0.8U_n - 1.15U_n$	$0.8U_n - 1.15U_n$
Nominal frequency		50 Hz	50 Hz
Nominal (base) current		5 A	5 A
Maximal current		6 A	6 A
Transient current		250 mA	250 mA
Minimal current		50 mA	50 mA
Starting current		5 mA	5 mA
Mode		static meter	static meter
Power consumption per phase	voltage circuit	< 3W and 15 VA	< 3W and 15 VA
	current circuit	< 1 VA	< 1 VA
Number of tariffs		up to 4	up to 4
Pulse output		optical and electrical	optical and electrical
Constant of optical pulse output			
	for active energy	10.000 pulse/kWh	40.000 pulse/kWh
	for reactive energy	10.000 pulse/kvarh	40.000 pulse/kvarh
Constant of electrical pulse output			
	for active energy	5.000 pulse/kWh	20.000 pulse/kWh
	for reactive energy	5.000 pulse/kvarh	20.000 pulse/kvarh
Characteristic of electrical pulse output according to IEC62052-11 and IEC62053-31		voltage < 27 V, current < 27 mA	
Operating temperature		-25 °C to +55 °C	
Storage temperature		-40 °C to +80 °C	
Internal real time clock		(IEC 62052-21)	
Accuracy at 25 °C		< 0.5s/24h	
Backup operation time		> 10 years with Li battery	
Clock signal		Quartz crystal 32.768 kHz	
Communication interfaces			
Optical			
Data transfer rate		300 to 9600 bps	
Interface		IEC62056-21 mode C	
Protocol		IEC62056-46 DLMS/COSEM	
Register marking		IEC62056-61 OBIS	
Serial interface TTL level			
Data transfer rate		300 to 9600 bps	
Protocol		IEC62056-46 DLMS/COSEM	
Register marking		IEC62056-61 OBIS	
GSM/GPRS modem - option			
Data transfer rate		53.6 kB/s	
Protocol		IEC62056-46 DLMS/COSEM	
Register marking		IEC62056-61 OBIS	

Meter family	EWGE32x	EWGE34x
Average power demand		
Integration period - programmable	1, 5, 15, 30, 60 minutes (default 15 minutes)	
Reset	no external reset (software only)	
EMC according to IEC 62052-11		
Dielectric strength IEC60060-1	4 kV, 50 Hz, 1 min.	
Electrostatic discharge IEC61000-4-2	contact 8 kV, air 15 kV	
Electromagnetic fields IEC61000-4-3	10V/m - load, 30V/m - no load	
Burst test IEC61000-4-4	main terminals – 4 kV auxiliary terminals – 2 kV	
Surge test IEC61000-4-5	4 kV 1.2/50 μ s open voltage circuit 8/20 μ s short current circuit	
Immunity to conducted disturbances inducted by RF according to IEC 61000-4-6 §7.4.8	10 V/m	
Immunity to damped oscillatory waves according to IEC 61000-4-6 §7.4.10	2.5 kV – common mode 1 kV – differential mode	
Radio interference suppression according to IEC 61000-4-6 §7.4.13	EN55022	
Display		
Display type	seven-segmented liquid crystal display (LCD)	
Data values digits	8	
OBIS code digits	5	
Digits size data/OBIS	8 mm / 6 mm	
Display modes	Automatic / Manual / Test	
Total energy display digits	6 integer 2 decimal in Automatic/Manual mode 5 integer 3 decimal in Test mode for CT meter and 4 integer 4 decimal for CT/VT	
Average power demand	5 integer 3 decimal	
Phase voltage presence indicator	3 symbols L1, L2, L3	
Meter status indicator	5 symbols	
List of data displayed in automatic mode	programmable	
List of data displayed in manual mode	programmable	
Display period	programmable 5 to 20 second (default 8 sec.)	
Tariff control		
Internally	using build-in real time clock	
External - optional	using external device	
Number of tariff	2 up to 4	
Thermo-mechanical properties		
IP protection	IP54	
Relative humidity (indoor mounting)	Annual average: $\leq 90\%$ up to 40°C Boundary conditions: $\leq 95\%$ up to 40°C Storage and transport: $\leq 95\%$ up to 40°C	

Meter family	EWGE32x	EWGE34x
Capacity of measured/registered value profile memory	4 profiles, 6 channels	
Billing profile (max 33 channels)	18 records	
Load profile with recording period 1	5760 records	
Load profile with recording period 2	1440 records	
Load profile with recording period 3	100 records	
Load profile during test	1000 records	
Logs		
Standard event log	200 records	
Power quality log	100 records	
Integrity violation log	30 records	
Disconnect log	20 records	
Communication log	100 records	
Power failure log	10 records	



1.1.3. Standards and references

IEC 62052-11	Electricity meter equipment (AC): General requirements, tests and test conditions - Part 11: Metering equipment
IEC 62053-21	Electricity metering equipment (a.c.) –Particular requirements Part 21: Static meters for active energy (classes 1 and 2)
IEC 62053-22	Electricity metering equipment (a.c.) –Particular requirements Part 22: Static meters for active energy (classes 0,2 S and 0,5 S)
IEC 62053-23	Electricity metering equipment (a.c.) –Particular requirements Part 23: Static meters for reactive energy (classes 2 and 3)
EN 50470-1	Electricity metering equipment (a.c.) —Part 1: General requirements, tests and test conditions - Metering equipment (class indexes A, B and C)
EN 50470-3	Electricity metering equipment (a.c.) —Part 3: Particular requirements — Static meters for active energy(class indexes A, B and C)
IEC 62056-21	Electricity metering - Data exchange for meter reading, tariff and load control Part 21:Direct local data exchange
IEC 62056-42	Electricity metering - Data exchange for meter reading, tariff and load control Part 42:Physical layer services and procedures for connection-oriented asynchronous data exchange
IEC 62056-46	Electricity metering - Data exchange for meter reading, tariff and load control Part 46: Data link layer using HDLC-Protocol
IEC 62056-47	Electricity metering - Data exchange for meter reading, tariff and load control Part 47: COSEM transport layer for IP networks
IEC 62056-53	Electricity metering - Data exchange for meter reading, tariff and load control Part 53: COSEM application layer
IEC 62056-61	Electricity metering - Data exchange for meter reading, tariff and load control Part 61: OBIS object identification system
IEC 62056-62	Electricity metering - Data exchange for meter reading, tariff and load control Part 62: Interface classes
DIN 43856-1989	Electricity meters, tariff time switchers and ripple control receivers; connection diagrams, terminal marking, circuit diagrams
DIN 43857	Wathour meters in moulded insulation case without instrument transformers up to 60 A rated maximum current
IEC 60529	Degrees of protection provided by enclosures (IP Code)
IEC13757-2	Communication system for meters and remote reading of meters part 2:physical and link layer
IEC13757-3	Communication system

2. Design of the meter

A compact meter case consist of:

- meter base with a terminal block
- meter cover
- terminal cover
- fixing elements for mounting the meter
- additional module case (for PLC, GPRS, RF, RS485 modules etc.)

2.1. Meter housing (construction)

The meter case is made of high quality self-extinguishing UV stabilized polycarbonate reinforced with 10% glass fibre, except for the transparent meter case cover. Terminal block is constructed as a removable with current clamps with one screw according to IEC 62052 – 11. The meter base has place to hold the electronic boards, protected by the manufacturer seals. There is also a place for the external communication module. The meter has IP52 protection level against dust and water penetration, in compliance with IEC 60529 standard.

2.1.1. Front and bottom view

Figure 2.1 shows a meter with terminal cover.

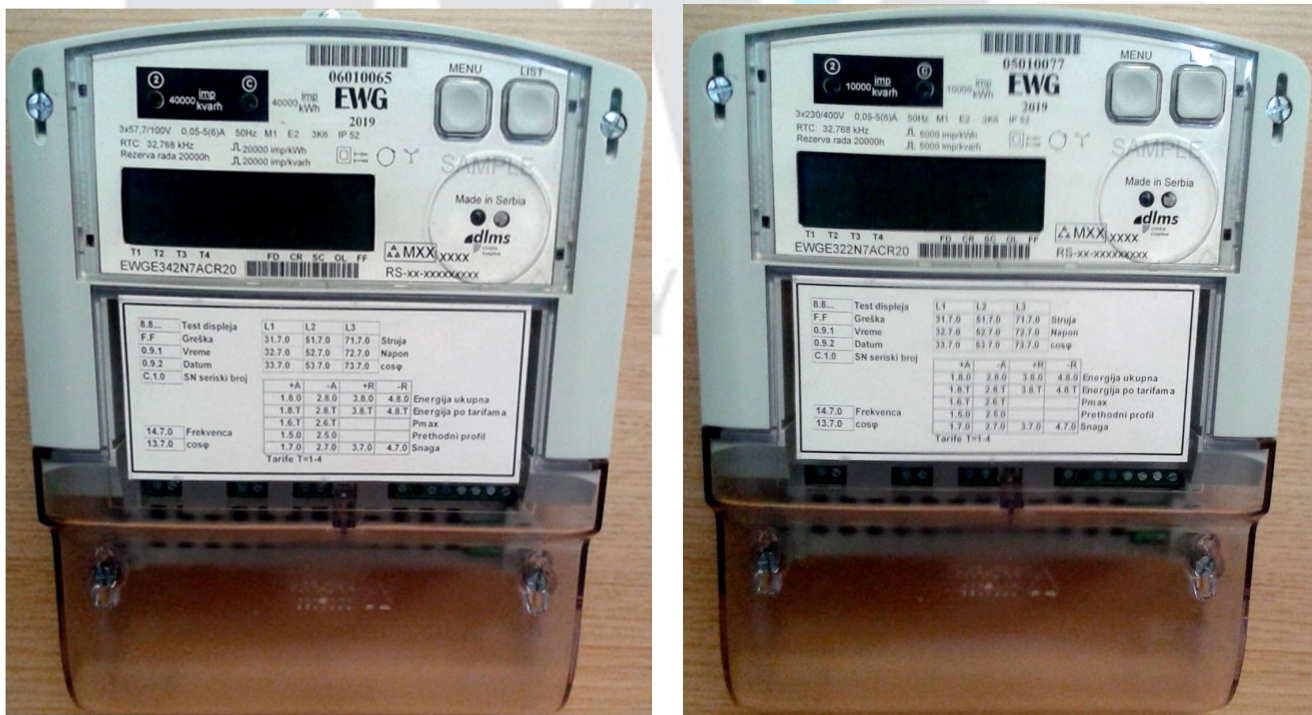

Figure 2.1 EWG meter (EWGE34x left and EWGE32x right) – front view

2.1.2. Overall meter housing dimensions

Meter dimensions and hanging points are according to DIN 43 857, as shown in Figure 2.2.

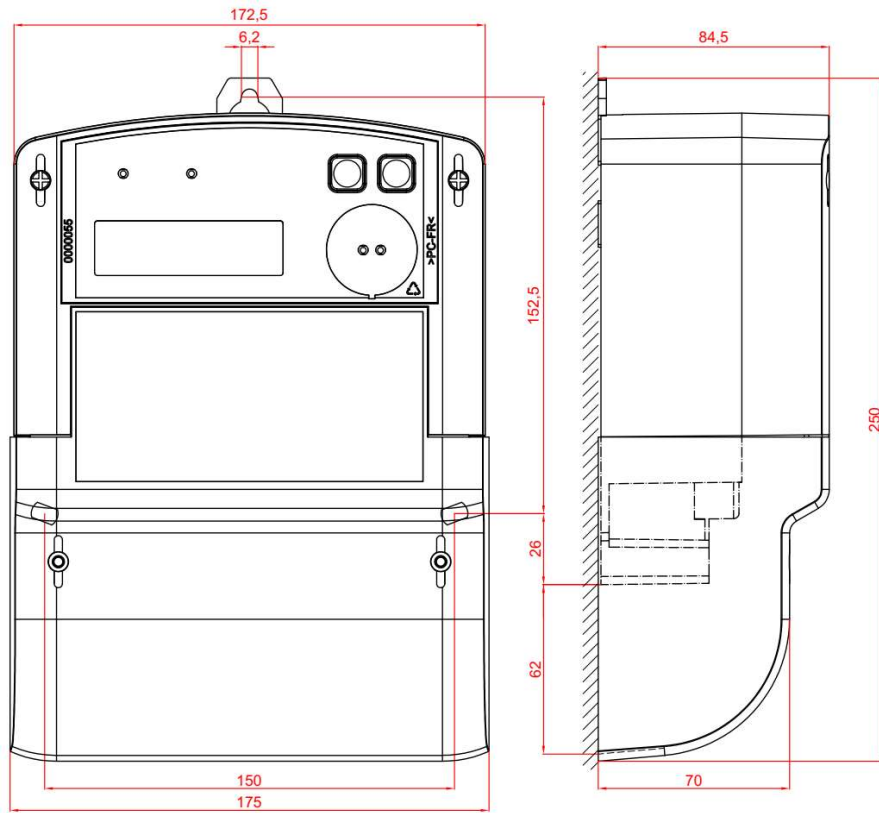

Figure 2.2. Dimensions of the meter

Table 2.1 External dimensions of the meter (in mm)

label	b1	b2	b3	h1	h2	h3	h4	c
dimension [mm]	150±1	175	172.5	152.5	178	250	65	84.5

2.1.3. Terminal block

The terminal block complies with the DIN 43857 standard. It is made of self-extinguishing high quality polycarbonate. Terminal block current terminals are made of brass. The surface of terminals can be additionally protected with nickel for the areas with extreme climatic conditions (e.g. tropical area).

Screws are made of zinc plated steel with pozidrive No.2 head type. The conductors can be fixed with one screw per terminal.

Auxiliary terminals are intended for the connection shown in Table 2.2:

Table 2.2 Auxiliary terminal labels

TERMINAL	LABEL
TARIFF INPUTS	
tariff input 1	51
tariff input 2	52
ELECTRICAL TEST OUTPUT	
SO-a/ SO-r negative	53
SO-a positive	54
SO-r positive	55
RELAY 1	
input	61
output	62
RELAY 2	
input	63
output	64
RS485	
input	A
output	B

Dimension and labels of terminal block are shown on figures 2.3 and 2.4.

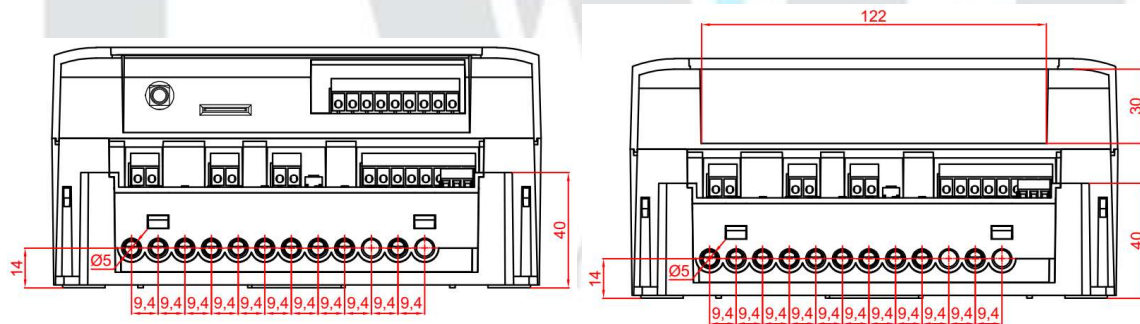

Figure 2.3 Meter terminal dimensions (with GPRS modem left, without modem right)

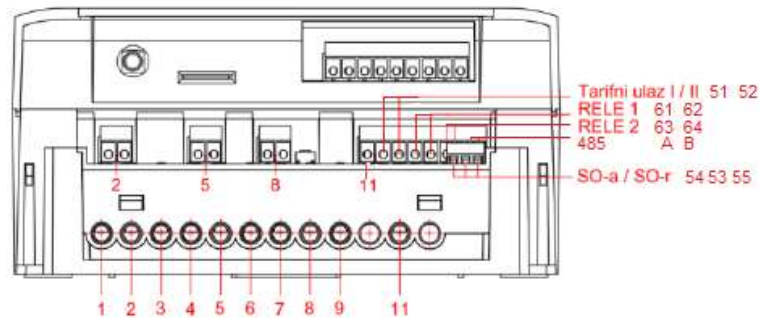

Figure 2.4 Meter terminal connector's labels (with GPRS modem)

2.2. Meter labels

2.2.1. Name plate

Basic meter's data are shown on the name-plate, located on the front of the meter and printed using an indelible method. Name plate of EWGE32x and EWGE34x family meters has shown on figure 2.5.

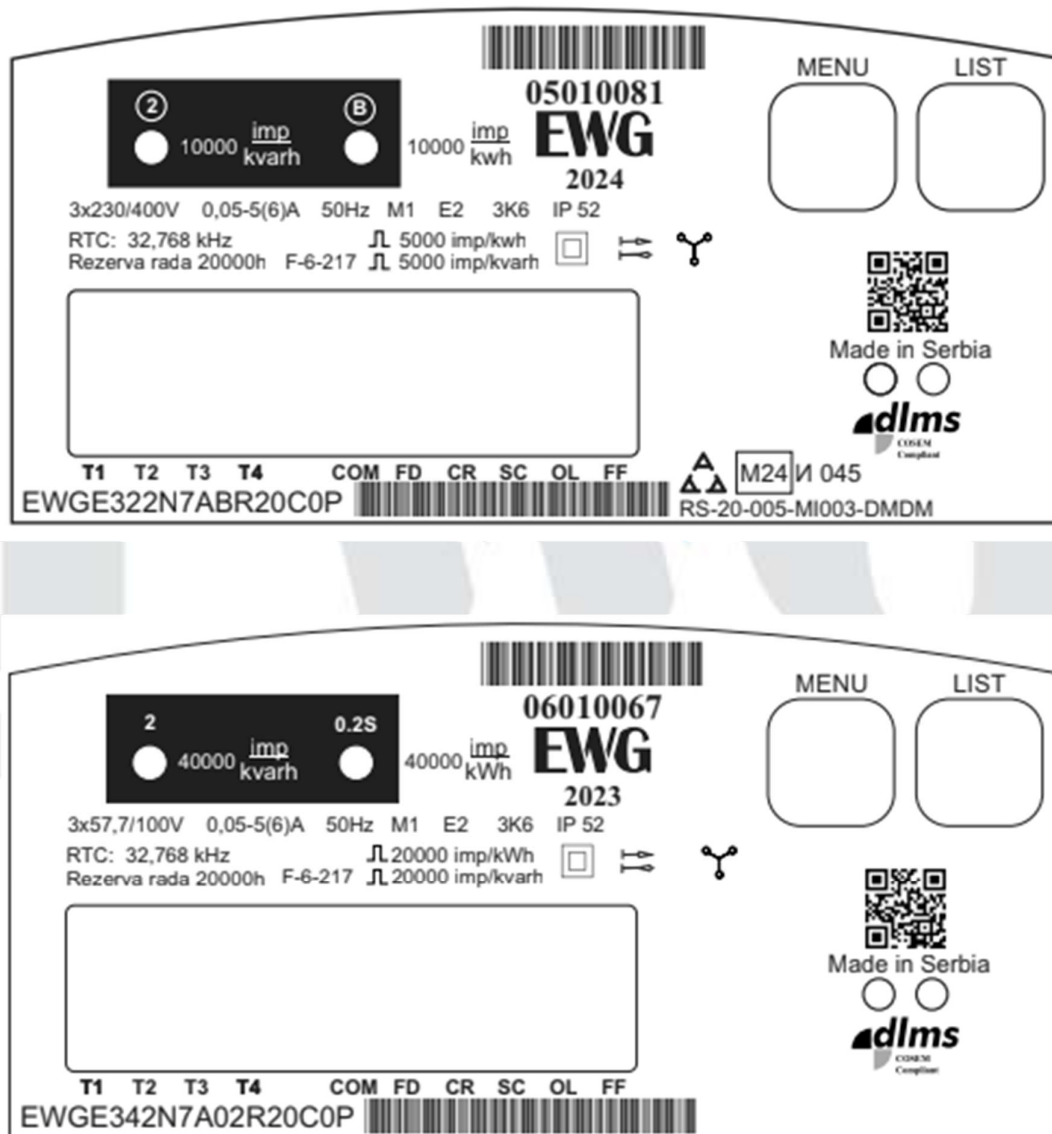

Figure 2.5 Name plates of EWGE32x and EWGE34x meters

Table 2.3 List of data printed on name-label

Item	Description
1	Name of the manufacturer
2	Rated accuracy class
3	Year of manufacture
4	Barcode with the meter serial number
5	Serial number
6	Constants of optical output impulses
7	Type approval label (official label of the competent authority)
8	Certificate number
9	Meter type label
10	Reference voltage
11	Minimum, rated and maximum current
12	Rated frequency
13	Barcode with the meter type
14	Constants of electrical output impulses
15	Protection class label IP52
16	Class II insulation level label
17	Mechanical protection class M2
18	Electromagnetic protection class E2
19	Temperature range 3K6
20	Communication protocol

2.2.2. OBIS code plate

OBIS code plate is located on terminal block cover and is shown in the Figure 2.6.

8.8...	Display test						
F.F.	Error						
0.9.1	Time						
0.9.2	Date						
C.1.0	Serial number						
		 +A + -A 	+A	-A	+R	-R	
		15.8.0	1.8.0	2.8.0	3.8.0	4.8.0	Energy total
		15.8.x	1.8.x	2.8.x	3.8.x	4.8.x	Energy in tariff x
			1.6.x				P_{max} in tariff x
14.7.0	Frequency		1.5.0				Last demand
13.7.0	cos(φ)		1.7.0	2.7.0	3.7.0	4.7.0	Power
		Tariff: x = 1, 2, 3, 4					

Figure 2.6 OBIS code plate for EWGE32x and EWGE34x family meters

2.2.3. Connection diagram

The meter connection diagrams for the transformer operated meters EWGE32x and EWGE34x (connection over current and voltage transformers) is shown on the Figures 2.7 to 2.9.

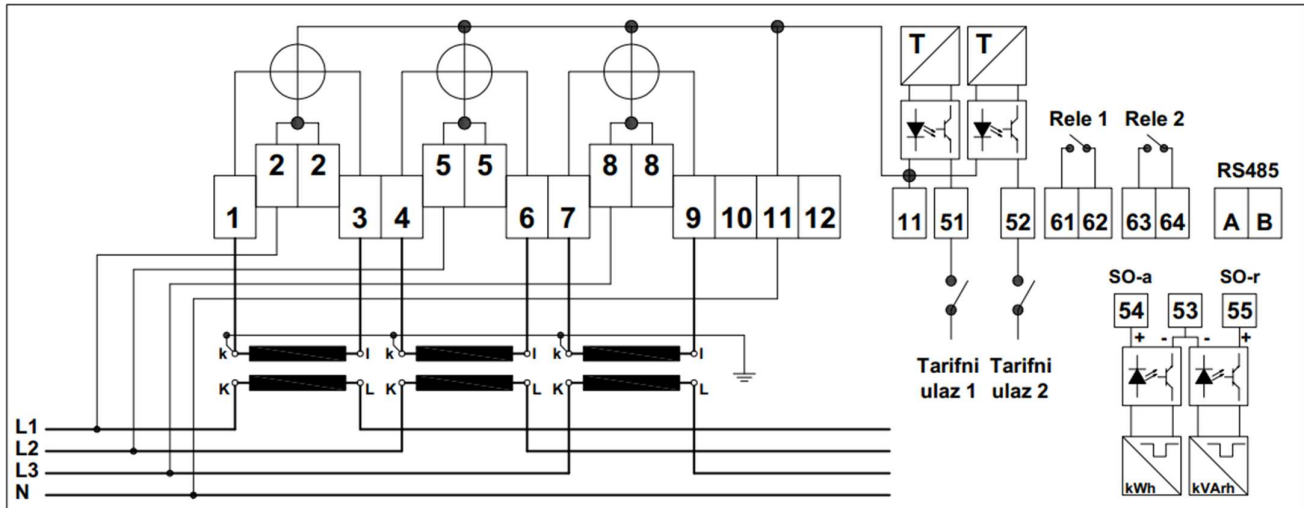

Figure 2.7 Current transformer operated meter connection scheme

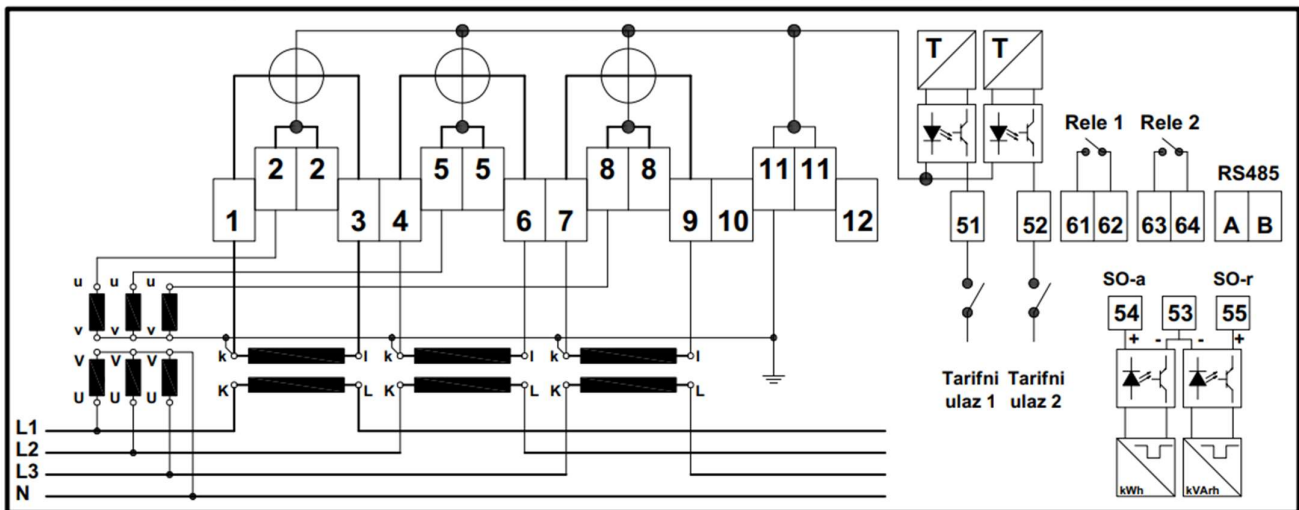

Figure 2.8 Current and voltage transformer operated meter connection scheme

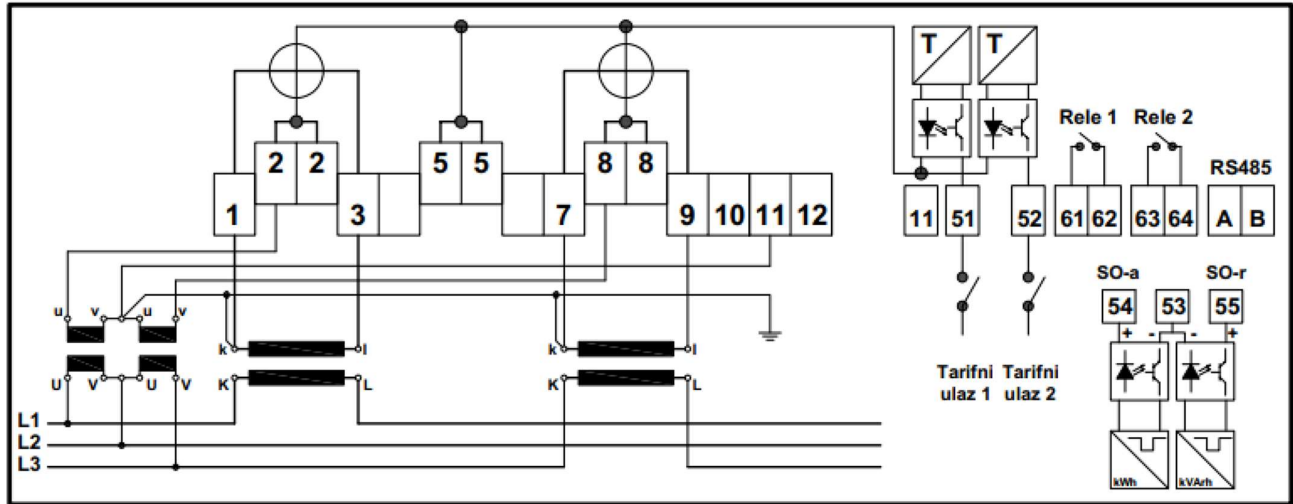

Figure 2.9 Current and voltage transformer operated meter Aaron connection scheme

2.3. Additional module case – communication modules

The communication module case is made of 10% glass fiber reinforced polycarbonate. The module case dimensions that the meter base can hold are 30x60x122mm. It is designed to hold different types of communication modules as PLC, GPRS, RF, RS485. The module case is covered by the transparent terminal block cover. The module is protected by the utility seal(s).

2.4. Sealing

The meter cover can be sealed with two sealing screws. Usually after the process of the metrological testing in authorized laboratory manufacturer put own seals on meter case cover.

The terminal cover also can be sealed on both of two screws (usually utility seals).

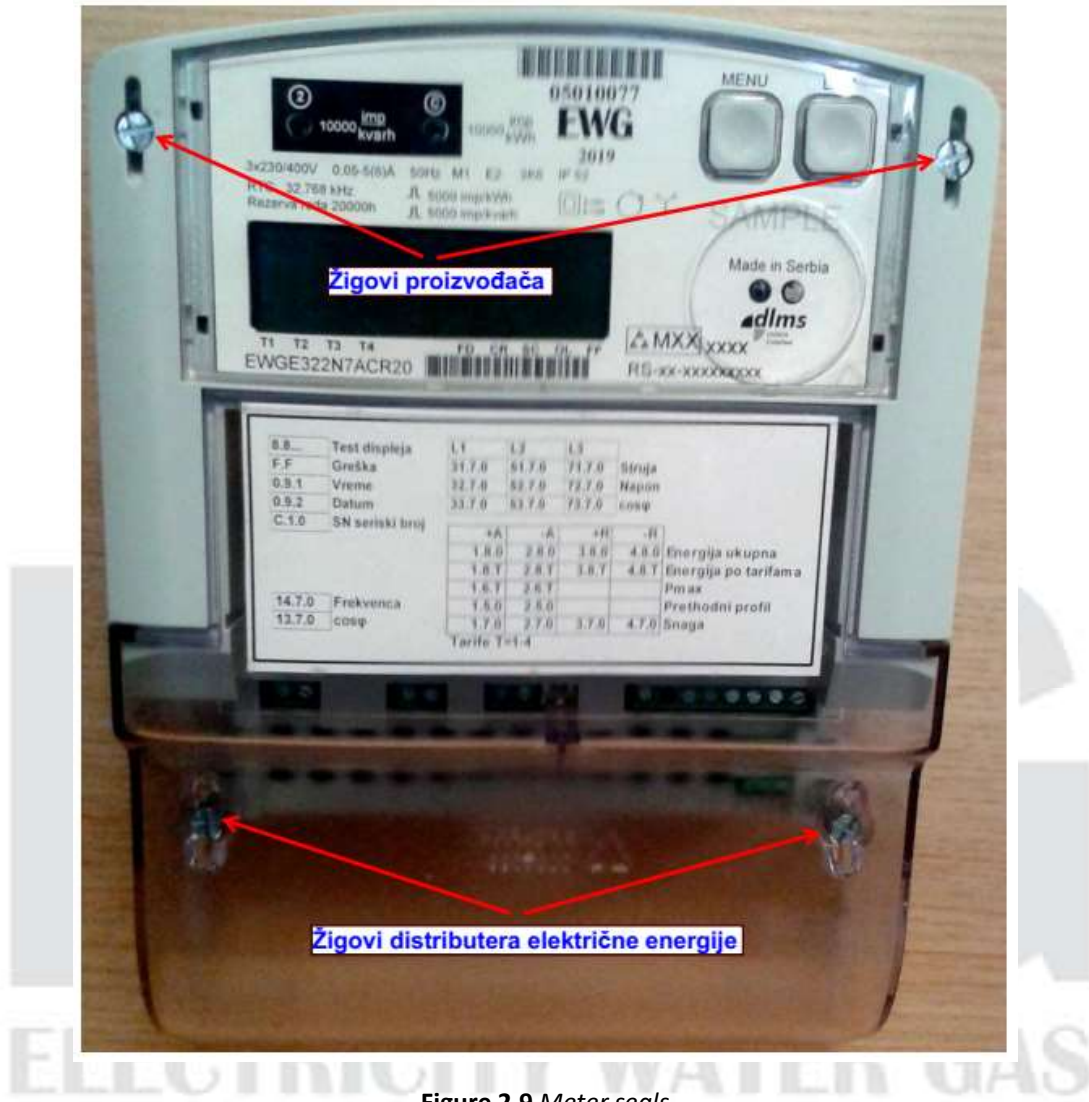

Figure 2.9 Meter seals

3. Electronic boards – PCB's

EWG meters consist of two main electronic boards inside the meter case and additional communication board in external module case:

- upper board – display/measuring board - hardware version marked EWGDST95 and
- lower board – power board with external tariff inputs, test outputs, relay outputs and sensors - hardware version marked EWG3MG32.

3.1. Upper electronic board

Upper board hosts the measurement chip 71M6533H and the communication chip STM32F071 as well as display. Figure 3.1 shown block diagram of two main microcontrollers.

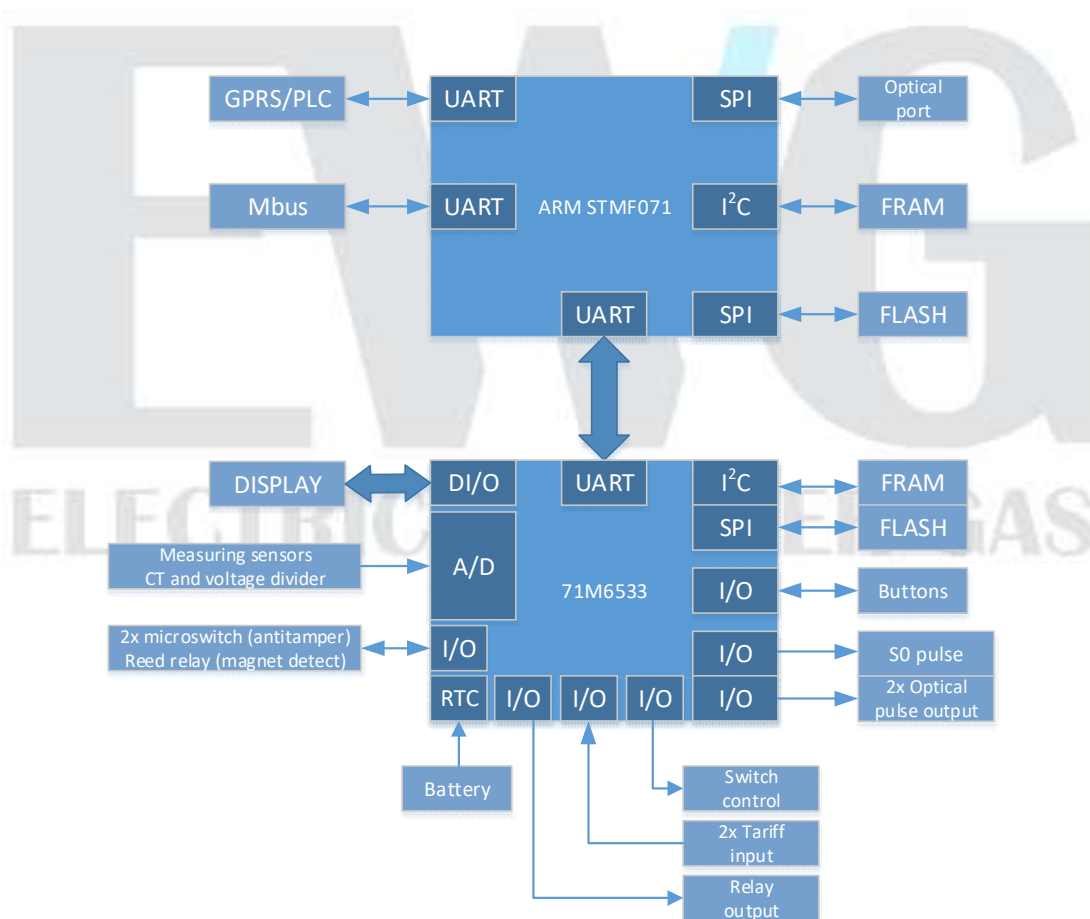

Figure 3.1 Microcontrollers block diagram

The measuring system based on the energy meter "system on chip" (SoC) Teridian 71M6533H which integrates all primary functional blocks required to implement a solid-state electricity meter. Included on the chip:

- analogue front end (AFE) with 22 bit $\Delta\Sigma$ AD converter
- independent digital 32 bit computation engine (CE)
- 8051-compatible microprocessor (MPU)
- LCD drivers
- RAM and Flash memory
- real time clock (RTC)
- variety of I/O pins

3.1.1. Signal input pins

EWGE32x and EWGE34x family meters are based on the three measurement systems with three voltage and three current channels. The current channels use current transformers as a sensors and voltage channels use voltage dividers. All analogue signal input pins are voltage sensitive. The voltage pins $V_A - V_B - V_C$ is single-ended. Current pin $I_{AP}/I_{AN} - I_{BP}/I_{BN} - I_{CP}/I_{CN}$ in EWG application is programmed to be differential.

3.1.2. Analogue front end (AFE)

The AFE functions as a data acquisition system, controlled by the microprocessor (MPU). The main blocks in the AFE consist of an input multiplexer, a delta-sigma A/D converter, a FIR decimation filter and a voltage reference. The analogue input signals are multiplexed before being sampled by the A/D converter. The A/D converter output is decimated by the FIR filter and the results are stored in XRAM where they can be accessed by the computation engine (CE) and the microprocessor (MPU).

3.1.3. Digital computation engine (CE)

The computation engine (CE), a dedicated 32-bit digital signal processor, performs the back-end computations. The CE calculations include:

- Multiplication of each current sample with its associated voltage sample to obtain the energy per sample (when multiplied with the constant sample time)
- Gain and offset compensation
- Delay compensation on all channels (caused by the multiplexing scheme)
- 90° phase shift for VAR calculations
- Frequency measurement
- Accumulation for voltage and current RMS and power computation
- Active, reactive, apparent, fundamental, and harmonic power calculation
- Fundamental and harmonic current and voltage calculations
- Monitoring of the input signal frequency (for frequency and phase information)
- Monitoring of the input signal amplitude (for sag detection)
- Temperature acquisition

3.1.4. 80515 microprocessor core (MPU)

The 71M6533 include an 80515 MPU (8-bit, 8051-compatible) that processes most instructions in one clock cycle. Using a 10 MHz clock results in a processing throughput of 10 MIPS.

The 80515 MPU core incorporates the Harvard architecture with separate code and data spaces. Memory organization in the 80515 is similar to that of the industry standard 8051. There are four memory areas: Program memory (Flash, shared by MPU and CE), external RAM (Data RAM, shared by the CE and MPU), Configuration RAM and internal data memory (Internal RAM).

3.1.5. ARM microprocessor (core M0)

The STM32F071 microcontroller incorporate the high-performance ARM® Cortex®- M0 32-bit RISC core operating at up to 48 MHz frequency, high-speed embedded memories, and an extensive range of enhanced peripherals and I/O.

On the upper board (display-metering module)

- optical port for local communication,
- optical test output – two LED diodes,
- two navigation buttons (MENU and LIST),
- micro-switch for meter cover opening detection.

3.1.6. Optical test output

Optical test output form two LEDs on the front end of the meter. One LED is used for active energy and second one is reserve for reactive energy. Optical test output is intended for the meter calibration and accuracy testing.

The distance between two diodes is 25 mm and it is sufficiently long to avoid any interference. The shape of optical test diodes is round diameter 5 mm, and do not exceed the top cover.

Optical test output is in conformance with IEC 62052-11 standard §5.11. Pulses are not modulated and have waveforms as described in figure 3.2 below:

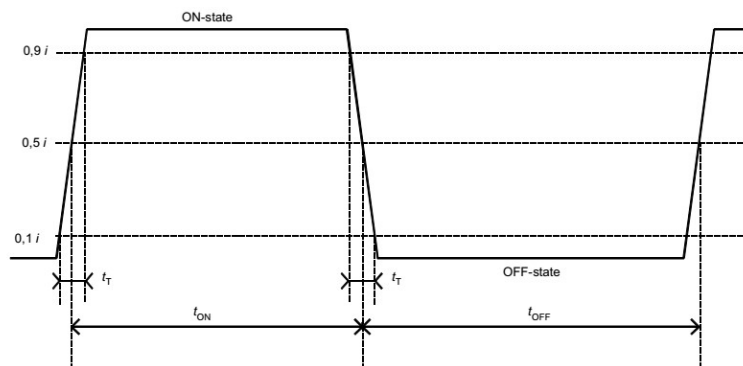

Picture 3.2 Waveform of the optical test output

where $t_{ON} \geq 0.2$ ms, $t_{OFF} \geq 0.2$ ms and $t_T < 20$ μ s.

For EWGE32x family meters constant of optical test output is 10000 pulse/kWh for active energy and 10000 pulse/kVAh for reactive energy. For EWGE34x family meters constant of optical test output is 40000 pulse/kWh for active energy and 40000 pulse/kVAh for reactive energy.

Maximum number of pulses is 16 per second.

3.1.7. Meter buttons

Two buttons, labelled MENU and LIST, located on the front side of the meter used for navigation through data displayed on the LCD. Browsing algorithm has shown in chapter 4.2.

3.2. Lower electronic board

The lower electronics board provides connection on the grid through the current and voltage sensors (current measurement transformers, voltage dividers). Main power supply for the meter itself as well as for the external modules located on lower electronic board.

More on the lower electronics board (power module):

- electrical pulse test output,
- external tariff input,
- auxiliary relay output,
- micro-switch for the terminal cover opening detection,
- sensor for magnetic field detection and
- electrical communication port.

3.2.1. Power supply

The power source is designed in such a way as to enable uninterrupted meter operation even in the case of disconnection in the neutral conductor, or in the event of detection of a phase/neutral conductor crossing.

3.2.2. Electrical test output

The meter has the electrical test output connected to the terminal pins labelled as 53, 54 and 55 according to Table 2.2.

Electrical test output is optically isolated and passive.

Pulse output specifications are according to IEC 62053-31 and IEC 62052-11 standards:

- open collector,
- maximum voltage 27 V,
- maximum current in ON-state 27 mA,
- minimum current in ON-state 10 mA,
- maximum current in OFF-state 2 mA,

Pulse duration is set on 40 ms. This is factory setting, and can be changed during process of initialization of the meter. For EWGE34x meters family SO constant is 20000 pulses/kWh for active energy and 20000 pulses/kVARh for reactive energy. For EWGE32x meters family SO constant is 5000 pulses/kWh for active energy and 5000 pulses/kVARh for reactive energy.

3.2.3. Auxiliary relay

The meter is equipped with two one-pole auxiliary relays with maximum switching current of 5 A at 230 V, located on the two two-pole terminal blocks located in meter terminal, labelled according to Table 2.2. The pole of the relay terminal block has one fixing screw. The section of the acceptable conductors is at most of 2.5 mm². Second relay is optional.

The control output is typically activated from the center or in accordance with the current tariff programme. However, activation of control output is programmable.

3.3. Meter communication ports

The EWG meter has three independent communication channels:

- Infrared optical port
- Electrical interface No. 1 – external module communication port
- Electrical interface No. 2 – external switching device port
- Electrical interface No. 3 – HAN (Home Area Network) port (option)

3.3.1. Optical port

The meter has build-in optical communication port used for local meter data readouts and settings via hand-held units (HHU).

The optical port operates in accordance with the standard for direct local data exchange IEC 62056-21. On the physical layer optical interface operates according to IEC 62056-21 mod C and on the application layer complies with IEC 62056-46 DLMS/COSEM communication protocol. The communication is achieved using HDLC common interface.

3.3.2. Electrical communication port

Electrical communication channel is implemented on TTL level serial interface. The meters family EWGE32x and EWGE34x uses GPRS modules for external communication. GPRS modules integrates RS485 interface.

Optionally GPRS module can integrate HAN interface.

Electrical communication channel as well as RS485 and HAN interface are optically isolated.

4. LCD - data display procedure

4.1. Display

The seven-segmented liquid crystal display (LCD) fully complies with the VDEW requirements.

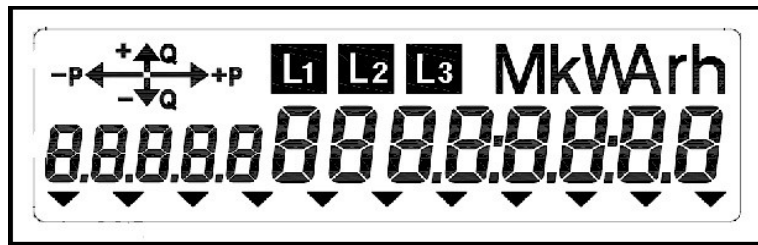

Figure 4.1 The meter display

4.1.1. Alphanumeric fields (data value and OBIS code field)

Data value field is used for presentation of the data values and consists of eight 7-segmented digits. High of digits in the data value field is 8 mm.

OBIS code field is used for presentation of the OBIS identification codes of the displayed data and consists of five digits. High of the digits in OBIS code field is 6 mm.

4.1.2. Physical units field

Physical unit field shows physical units of data displayed in data value field. List of units can be shown in physical unit field is listed below:

kW, kWh, kVAr, kVAh, A, V.

4.1.3. Power flow direction cursors

There are four power flow direction cursors on the display:

- Positive active power flow +P,
- Positive reactive power flow +Q,
- Negative active power flow -P,
- Negative reactive power flow -Q.

4.1.4. Phase voltage presence indicator

Segments L1, L2 and L3 show the presence of appropriate phase voltages.

In case of irregular connections:

- The reverse connection of input-output conductors causes appropriate phase indicator blinking at frequency of 1 Hz.
- Swapping of phase and neutral conductors causes all three phase indicators blinking at frequency of 1 Hz.
- Absence of phase voltage causes appropriate phase indicator fade-out. Voltage drop below 50% of nominal voltage is valued as the absence of corresponding phase voltage. This is default parameter and can be changed.

4.1.5. Tariff and error cursors

On the name-plate (below the LCD) the meter has printed labels that belong to the cursor on the LCD. The cursor shows the active tariff and the state of certain functions or errors of the meter.

LC – load control

FD – fraud detection

CR – code red activated

SC – switch disconnected

OL – power limit exceeded (overload)

FF – fatal error (meter failure)

4.2. Data Display Procedure

The meter's data can be displayed in one of the three operating modes:

- automatic
- manual
- test

Default operating mode is automatic.

Navigation through data displayed on LCDs carried out by two keys MENU and LIST. Navigation diagram is shown in Figure 4.2. Transition time between displays:

- t1 = 8 seconds,
- t2 = 20 seconds.

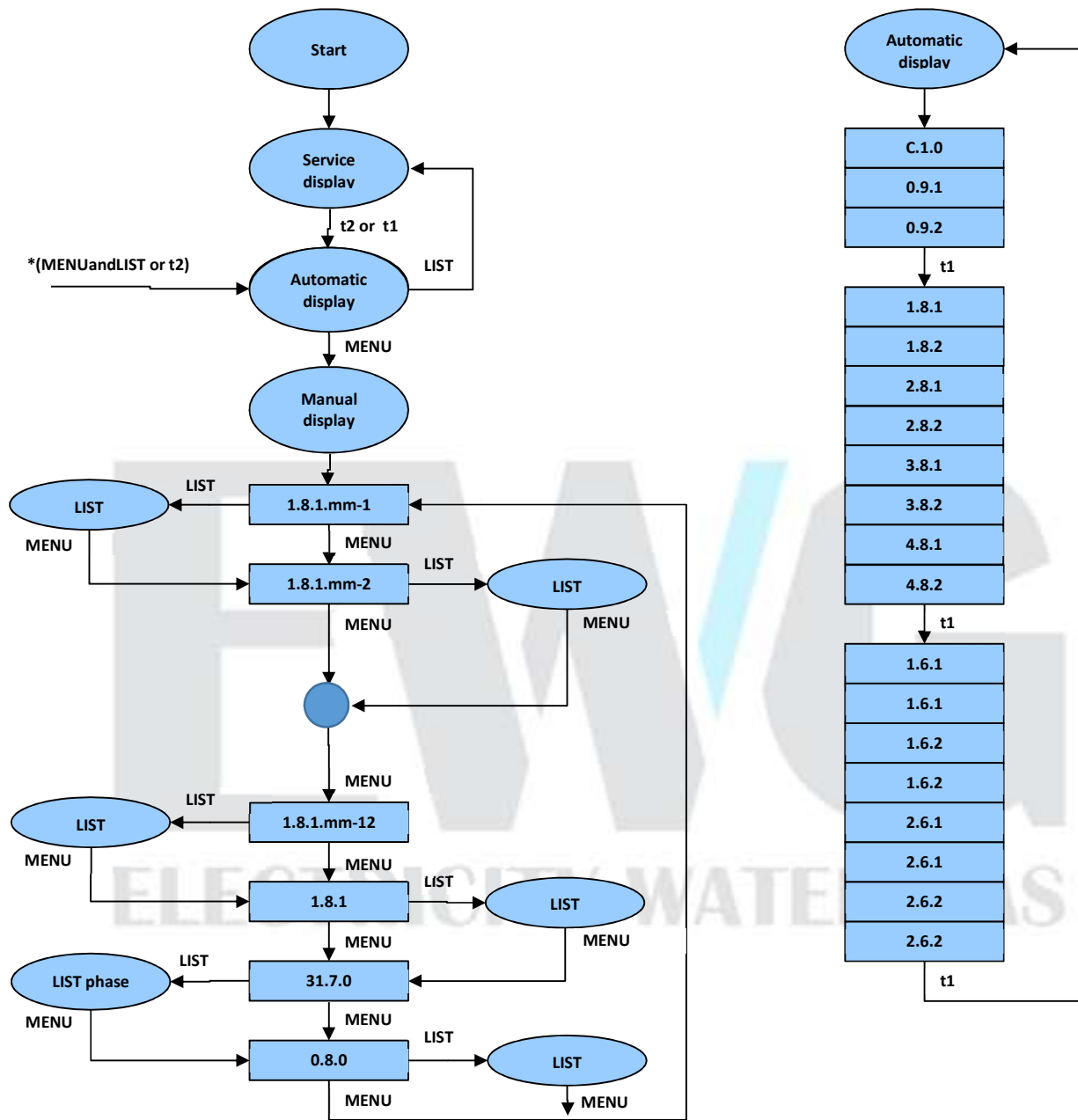

Figure 4.2 Display navigation diagram

By pressing MENU key meter switches from automatic to the manual mode. The appropriate menu can be selected by pressing of MENU key repeatedly.

If meter works in automatic mode, by pressing LIST key display switches to test mode. If meter works in manual mode by pressing LIST key different data is shown from the chosen menu.

Transition from manual or test mode to default (automatic) mode can be done by simultaneous pressing MENU and LIST keys for 2 seconds if terminal cover is set on the meter or automatically after 20 seconds if no one key is pressed.

The navigation keys MENU and LIST are used for navigation through the data and may not affect the data itself.

4.2.1. Automatic mode

In automatic mode, the measured values are displayed in cycles with a programmable display period. Display period duration ranges from 5 to 20 seconds. Default value of the transition period is 8 sec.

The list of the data that can be displayed in automatic mode is given in Table 4.1. The order and the number of the data to be displayed is programmable. The initial display list is shown in Table 4.2.

Table 4.1

Ref. no. of the items in the list	OBIS CODE	Description	Class	Unit
1	F.F	Error code (meter failure only)	1	
2	C.1.0	Manufacturer's serial number	1	
3	0.9.1	Time – local	1	
4	0.9.2	Date – local	1	
5	1.8.0	Positive active energy A+ total	3	kWh
6	1.8.T	Positive(import) active energy (A+) in tariff T (T=1 to 4)	3	kWh
7	2.8.0	Negative active energy A- total	3	kWh
8	2.8.T	Negative active (export)energy (A-) in tariff T (T=1 to 4)	3	kWh
9	3.8.0	Positive reactive energy R+ total	3	kWh
10	3.8.T	Positive reactive (import)energy (R+) in tariff T (T=1 to 4)	3	kvarh
11	4.8.0	Negative reactive energy R- total	3	kWh
12	4.8.T	Negative reactive (export)energy (R-) in tariff T (T=1 to 4)	3	kvarh
13	1.6.0	Positive active maximum demand total	3	kWh
14	1.6.T	Positive active maximum demand (P_{max+}) with Time stamp in tariff T (T=1 to 4)	4	kW
15	2.6.0	Negative active maximum demand total	3	kWh
16	2.6.T	Negative active maximum demand (P_{max-}) with Time stamp in tariff T (T=1 to 4)	4	kW

Table 4.2

Ref. no. of the items in the list	OBIS CODE	Description	Class	Unit
1	F.F	Error code (meter failure only)	1	
2	C.1.0	Manufacturer's serial number	1	
3	0.9.1	Time – local	1	
4	0.9.2	Date – local	1	
5	1.8.1	Absolute active energy (A+) in tariff T1	3	kWh
6	1.8.2	Absolute active energy (A+) in tariff T2	3	kWh
7	2.8.1	Absolute active energy (A-) in tariff T1	3	kWh
8	2.8.2	Absolute active energy (A-) in tariff T2	3	kWh
9	3.8.1	Absolute reactive energy (R+) in tariff T1	3	kWh
10	3.8.2	Absolute reactive energy (R+) in tariff T2	3	kWh
11	4.8.1	Absolute reactive energy (R-) in tariff T1	3	kWh
12	4.8.2	Absolute reactive energy (R-) in tariff T2	3	kWh
13	1.6.1	Positive active maximum demand (P_{max+}) in tariff T1	4	kW
14	1.6.1	Time stamp	4	
15	1.6.2	Positive active maximum demand (P_{max+}) in tariff T2	4	kW
16	1.6.2	Time stamp	4	

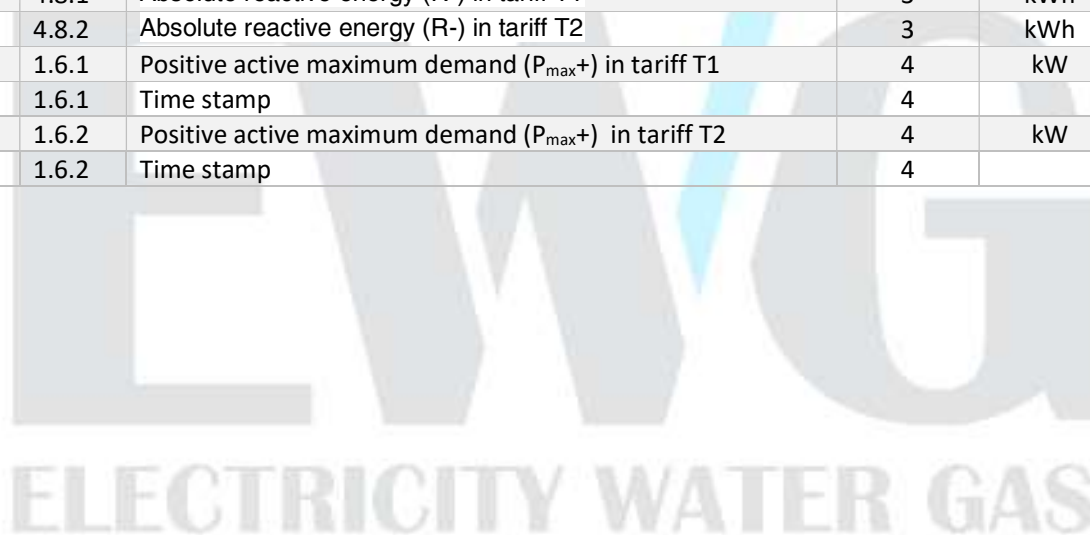

4.2.2. Manual mode

Manual mode gives a read-out of the data referring to billing, instantaneous power, voltage, current, frequency, power factor.

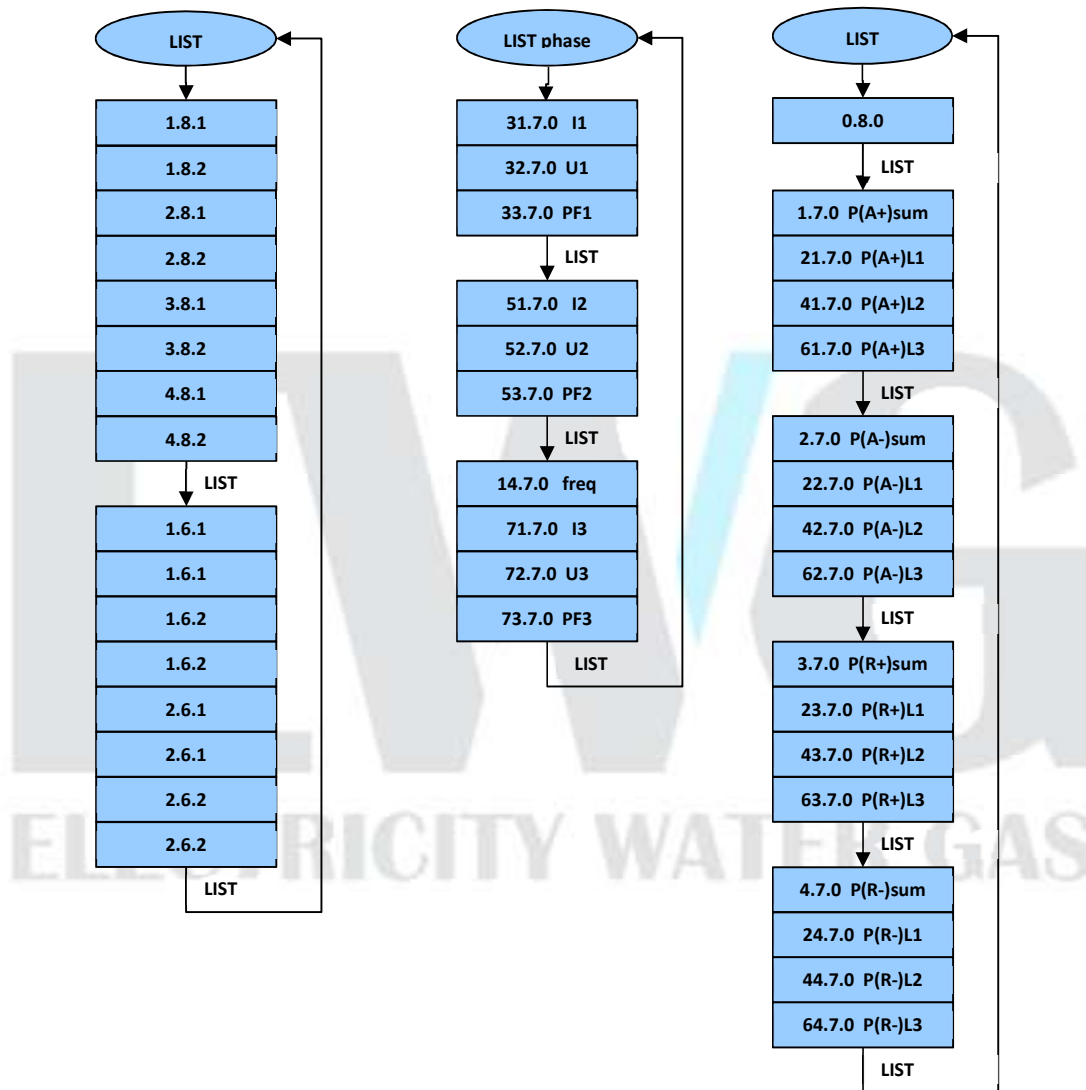

Figure 4.3 Display navigation diagram – manual mode

A list of possible items-OBIS codes intended for display in manual mode is given in Table 4.3. The order and number of the data presented in the list is programmable. The initial data list is shown in Table 4.4.

Table 4.3

Ref. no. of the items in the list	OBIS CODE	Description	Class	Unit
1	F.F	Error code (meter failure only)	1	
2	C.1.0	Manufacturer's serial number	1	
3	0.9.1	Time – local	1	
4	0.9.2	Date – local	1	
5	1.8.0	Positive active energy A+ total	3	kWh
6	1.8.Tvz	Positive active energy (A+) in tariff T* - last completed month	3	kWh
7	2.8.Tvz	Negative active energy (A-) in tariff T* - last completed month	3	kWh
8	3.8.T vz	Positive reactive energy (R+) in tariff T* - last completed month	3	kvarh
9	4.8.Tvz	Negative reactive energy (R-) in tariff T* - last completed month	3	kvarh
10	1.6.Tvz	Positive active power maximum demand (P_{max+}) in tariff T* - last completed month	4	kW
11	1.6.Tvz	Time stamp	4	
12, 13	2.6.Tvz	Positive active power maximum demand (P_{max+})with Time stamp in tariff T* - last completed month	4	kW
14	14.7.0	Frequency	3	Hz
15	1.7.0	Total positive active instantaneous power (P+)	3	kW
16	90.7.0	Total current (all three phase sum)	3	A
17	31.7.0	Instantaneous current (I) in phase L1	3	A
18	32.7.0	Instantaneous voltage (U) in phase L1	3	V
19	51.7.0	Instantaneous current (I) in phase L2	3	A
20	52.7.0	Instantaneous voltage (U) in phase L2	3	V
21	71.7.0	Instantaneous current (I) in phase L3	3	A
22	72.7.0	Instantaneous voltage (U) in phase L3	3	V
23	21.7.0	Positive active instantaneous power (P+) in phase L1	3	kW
24	41.7.0	Positive active instantaneous power (P+) in phase L2	3	kW
25	61.7.0	Positive active instantaneous power (P+) in phase L3	3	kW

* Tariff T= 1 to 4

Table 4.4

Ref. no. of the items in the list	OBIS CODE	Description	Class	Unit
1	F.F	Error code (meter failure only)	1	
2	C.1.0	Manufacturer's serial number	1	
3	0.9.1	Time – local	1	
4	0.9.2	Date – local	1	
5**	1.8.1 vz	Positive active energy (A+) in tariff T1 - last completed month	3	kWh
6*	1.8.2vz	Positive active energy (A+) in tariff T2 - last completed month	3	kWh
7*	2.8.1 vz	Negative active energy (A-) in tariff T1 - last completed month	3	kWh
8*	2.8.2vz	Negative active energy (A-) in tariff T2 - last completed month	3	kWh
9*	3.8.1 vz	Positive reactive energy (R+) in tariff T1 - last completed month	3	kWh
10*	3.8.2vz	Positive reactive energy (R+) in tariff T2 - last completed month	3	kWh
11*	4.8.1 vz	Negative reactive energy (R-) in tariff T1 - last completed month	3	kWh
12*	4.8.2vz	Negative reactive energy (R-) in tariff T2 - last completed month	3	kWh
13, 14	1.6.1vz	Positive active power maximum demand (P_{max+}) with Time stamp in tariff T1 - last completed month	4	kW
15, 16	1.6.2vz	Positive active power maximum demand (P_{max+}) with Time stamp in tariff T2 - last completed month	4	kW
17*	31.7.0	Instantaneous current (I) in phase L1	3	A
18*	32.7.0	Instantaneous voltage (U) in phase L1	3	V
19*	33.7.0	Instantaneous power factor($\cos \varphi$) L1	3	
20*	51.7.0	Instantaneous current (I) in phase L2	3	A
21*	52.7.0	Instantaneous voltage (U) in phase L2	3	V
22*	53.7.0	Instantaneous power factor($\cos \varphi$) L2	3	
23*	14.7.0	Frequency	3	Hz
24*	71.7.0	Instantaneous current (I) in phase L3	3	A
25*	72.7.0	Instantaneous voltage (U) in phase L3	3	V
26*	73.7.0	Instantaneous power factor($\cos \varphi$) L3	3	
27*	81.7.1	Instantaneous phase angle U1-U2	3	
28*	81.7.2	Instantaneous phase angle U1-U3	3	
29*	81.7.4	Instantaneous phase angle U1-I1	3	
30*	81.7.5	Instantaneous phase angle U1-I2	3	
31*	81.7.6	Instantaneous phase angle U1-I3	3	
32*	0.8.0	Measurement period 1 (integration period)	3	s
33*	1.7.0	Positive active instantaneous power (P+)	3	kW
34*	21.7.0	Positive active instantaneous power (P+) in phase L1	3	kW
35*	41.7.0	Positive active instantaneous power (P+) in phase L2	3	kW
36*	61.7.0	Positive active instantaneous power (P+) in phase L3	3	kW
37*	2.7.0	Negative active instantaneous power (P-)	3	kW
38*	22.7.0	Negative active instantaneous power (P-) in phase L1	3	kW
39*	42.7.0	Negative active instantaneous power (P-) in phase L2	3	kW
40*	62.7.0	Negative active instantaneous power (P-) in phase L3	3	kW
41*	3.7.0	Positive reactive instantaneous power (P+)	3	kW

42*	23.7.0	Positive reactive instantaneous power (P+) in phase L1	3	kW
43*	43.7.0	Positive reactive instantaneous power (P+) in phase L2	3	kW
44*	63.7.0	Positive reactive instantaneous power (P+) in phase L3	3	kW
45*	4.7.0	Negative reactive instantaneous power (P-)	3	kW
46*	24.7.0	Negative reactive instantaneous power (P-) in phase L1	3	kW
47*	44.7.0	Negative reactive instantaneous power (P-) in phase L2	3	kW
48*	64.7.0	Negative reactive instantaneous power (P-) in phase L3	3	kW
37*	2.7.0	Negative active instantaneous power (P-)	3	kW
38*	22.7.0	Negative active instantaneous power (P-) in phase L1	3	kW
39*	42.7.0	Negative active instantaneous power (P-) in phase L2	3	kW
40*	62.7.0	Negative active instantaneous power (P-) in phase L3	3	kW
24	61.7.0	Positive active instantaneous power (P+) in phase L3	3	kW

***Press on LIST Key for list recorder data for particular month**

****Press on MENU key for scrolling down the monthly data list**

Scrolling down the monthly data list, key-press on the MENU for the last month billing data leads to information on monthly consumption for the month-2. Successive key-press of the LIST gives an overview of the data recorded for that particular month, whereas pressing MENU moves to the next menu to display the data for the month-3. Data list overview comes to an end upon reaching data for the last (twelfth) month recorded.

4.2.3. Test mode

There are two test modes implemented; one for meter hardware validation and the other used in the process of verification of metrological characteristics of the meter. Position of the terminal block cover determines the test mode status.

If the terminal cover is placed on (normal functioning of the meter, meter installed in the field) Test Mode allows meter hardware validation. The test implies display check first, all display segments are turned on to run display check. Then, the meter hardware validation follows and the error message is being displayed reading out the Error Code status (memory integrity, measurement fault—exceeding voltage or current measurement range, theft attempt, strong magnetic field influence). This is followed by battery status check and in case of any fault detected, the corresponding Error Code appears on the display. Next, the validity of memory and metrology system is checked. Error code if exist is displayed .

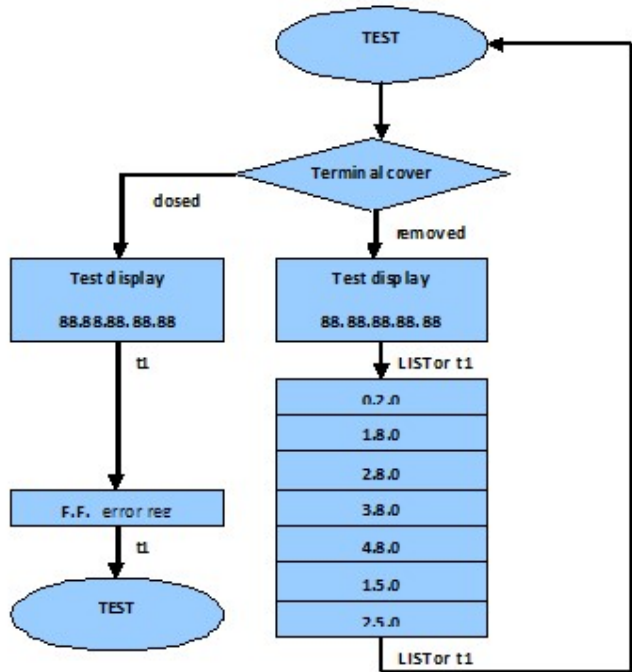

Figure 4.4 Display navigation diagram – test mode

In case of the terminal cover missing (meter in laboratory or authorized person on the field), key-press of the LIST enables entering the Test Mode for metrological characteristics check. In this mode, the display shows energy registers as shown in the Figure 4.4, with increased accuracy (one more decimal point) as shown in Table 4.5 and 4.6 for CT and CT/VT meters respectively.

Table 4.5

	INTEGERS	DECIMAL
1.8.0	5	3
2.8.0	5	3
3.8.0	5	3
4.8.0	5	3
1.5.0	2	3
2.5.0	2	3

Table 4.6

	INTEGERS	DECIMAL
1.8.0	4	4
2.8.0	4	4
3.8.0	4	4
4.8.0	4	4
1.5.0	2	3
2.5.0	2	3

Next succeeded key-presses of the LIST allows to preview values of this registers. After 20 seconds, if no other action, the meter display returns to automatic mode.

The meter self-diagnostics is run in case of:

- connection meter to the grid,
- return of a power supply,
- meter software update (when is possible and allowed),
- request from an authorized person with proper equipment (portable devices with an appropriate software).

5. Additional meter functions

5.1. Profiles of measured and registered values

The meter records and stores 4 data profiles:

- Billing profile –profile of monthly values of billing registers
- Load profile with recording period 1
- Load profile with recording period 2
- Load profile with recording period 3
- Load profile during test

Table 5.1. Electricity data profile objects

Type	Object / Attr	Class Id	OBIS
Abstract objects - Billing period reset	Data of billing period 1	7	0-0:98.1.0.255
Electricity related objects - Profiles	Load profile with period 1	7	1-0:99.1.0.255
Electricity related objects - Profiles	Load profile with period 2	7	1-0:99.2.0.255
EWG	Load profile with period 3	7	1-0:99.2.1.255
EWG	Load profile during test	7	1-0:99.3.0.255
Abstract objects - Billing period reset	Predefined Scripts - MDI reset / end of billing period	9	0-0:10.0.1.255
Abstract objects - Billing period reset	End of billing period	22	0-0:15.0.0.255
EWG	Status register 1	1	0-0:96.10.1.255
EWG	Status register 2	1	0-0:96.10.2.255
EWG	Status register 4	1	0-0:96.10.4.255

5.1.1. Billing profile

Billing data (active and reactive imported and exported energy and maximum active power demand with date and time of supply, registered according to tariffs) are stored for the last 18 accounting periods (typically 18 months). Billing profile can record values of maximum current per phase as well as maximum and minimum phase voltage with time stamp. Value is stored in attribute 2 and time and date of occurrence in attribute 5 of class 4.

Table 5.2. Current and voltage data

Type	Object / Attr	Class Id	OBIS
EWG	L1 Current ; Max.	4	1-0:31.6.0.255
EWG	L1 Voltage; Min.	4	1-0:32.3.0.255
EWG	L1 Voltage; Max.	4	1-0:32.6.0.255
EWG	L2 Current ; Max.	4	1-0:51.6.0.255
EWG	L2 Voltage; Min.	4	1-0:52.3.0.255
EWG	L2 Voltage; Max.	4	1-0:52.6.0.255
EWG	L3 Current ; Max.	4	1-0:71.6.0.255
EWG	L3 Voltage; Min.	4	1-0:72.3.0.255
EWG	L3 Voltage; Max.	4	1-0:72.6.0.255

5.1.2. Load profile with recording period 1

Active power maximum demand values or energy register for all tariffs with time stamp and meter status are stored in load profile with recording period of 15 minutes. This is default value and recording period is changeable parameter (available 1, 5, 15, 30, 60 minutes). The memory storage capacity allows 5760 records in total with 10 channels for this profile.

5.1.3. Load profile with recording period 2

Active and reactive energy registers or active power maximum demand registers (according to tariffs) with time stamp and meter status are stored in load profile with recording period of one hour. This is default value and recording period is changeable parameter. The memory storage capacity allows 1440 records in total with 10 channels for this profile.

5.1.4. Load profile with recording period 3

Active and reactive energy registers or active power maximum demand registers (according to tariffs) with time stamp and meter status are stored in load profile with recording period of 24 hours. This is default value and recording period is changeable parameter. The memory storage capacity allows 100 records in total with 10 channels for this profile.

5.1.5. Load profile during test

Measured Value Profile records and registers voltage or current values - in all three phases. Initially voltage is set as the value for storing. Storage activation time is programmable (15 min. default). Storage capacity is maximum 1000 records. In addition to the values recorded, corresponding time stamps are registered as well.

5.2. Logs

Six types of logs are implemented in the meter:

- Standard event log 200 records
- Power quality log 100 records
- Integrity violation log 30 records
- Disconnect control log 20 records
- Communication log 100 records
- Power failure log 10 records

Table 5.3. Logs

Type	Object / Attr	Class Id	OBIS
Abstract objects - Errors & Alarms- Event logs	Standard Event Log	7	0-0:99.98.0.255
Electricity related objects - PQ- monitored values	Power Quality Log	7	0-0:99.98.4.255
Abstract objects - Errors & Alarms- Event logs	Fraud Detection Log	7	0-0:99.98.1.255
Abstract objects - Disconnecter- Load mgmt- Supervision	Disconnecter Control Log	7	0-0:99.98.2.255
EWG	Communication Log / Event log; #6	7	0-0:99.98.5.255
Electricity related objects - PQ- monitored values	Power Failure Event Log	7	1-0:99.97.0.255

5.2.1. Standard Event Log

Standard Event Log contains event codes with time stamps for following events:

- meter disconnection
- meter reconnection
- setting parameter for daylight saving time function (DST)
- setting up a new tariff system (calendar)
- time setting
- real time clock (RTC) error
- battery low voltage
- error register cleared
- alarm register cleared
- load profile cleared
- memory fault
- measuring system error
- new firmware loaded (if available)
- new firmware activated (if available)

5.2.2. Power quality log (sag and swell)

The meter registers the event of occurrence of overvoltage and undervoltage per phase as well as their termination. Overvoltage and undervoltage thresholds are programmable with the initial values:

- overvoltage > 15% Un
- undervoltage < 20% Un

The event of occurrence of over/undervoltage is recorded in **PowerQualityLog** with time stamp. Power quality log has memory storage capacity for 100 records.

5.2.3. Integrity violation log

The meter detects, records and stores unauthorised integrity violation events such as:

- terminal cover being opened
- meter cover being opened
- presence of a strong magnetic field in the vicinity of the meter > 200mT

IntegrityViolationLog stores event code and time stamp of integrity violation event, and has storage capacity of 30 records.

Opening the meter housing is detected even if the meter is disconnected from the grid. Event code for this kind of violation recorded in **IntegrityViolationLog** can be erased or reset in the authorised laboratory only.

Records for other event codes can be erased or reset only if the meter operates in Automatic Meter Reading system, following proper procedure.

5.2.4. Power failure log

The meter registers the occurrence of supply interruption comply to EN50160 standard. There are two types of supply interruptions:

- short-term – in case of duration of interruption is less than 3 minutes
- long-term – in case of duration of interruption is more than 3 minutes

Each occurrence of supply interruption event is recorded in **PowerFailure Event Log**.

In case of short-term supply interruption event occurrence, *Number_of_short-term_supply_interruption* registers (for affected phase and "in any of three phases"), incremented. As well, *Short-term_supply_interruption_duration* registers (for affected phase and "in any of three phases") are updated.

In case of long-term supply interruption event occurrence, *Number_of_long-term_supply_interruption* registers (for affected phase and "in any of three phases"), incremented. As well, *Long-term_supply_interruption_duration* registers (for affected phase and "in any of three phases") are updated.

PowerFailure Event Log contains time of occurrence and duration of supply interruptions in any phase.

Table 5.5. PowerFailure Event Log objects

Type	Object / Attr	Class Id	OBIS
EWG	No. of long power failures; in all three phases	1	0-0:96.7.5.255
EWG	No. of long power failures; in phase L1	1	0-0:96.7.6.255
EWG	No. of long power failures; in phase L2	1	0-0:96.7.7.255
EWG	No. of long power failures; in phase L3	1	0-0:96.7.8.255
Electricity related objects - PQ- monitored values	Number of long power failures in any phase	1	0-0:96.7.9.255
Electricity related objects - PQ- monitored values	Number of power failures in any phase	1	0-0:96.7.21.255
EWG	Man. Spec. / No. of short failures in ph1	1	0-0:96.7.129.255
EWG	Man. Spec. / No. Of short failures in ph2	1	0-0:96.7.131.255
EWG	Man. Spec. / No. of short failures in ph3	1	0-0:96.7.133.255
EWG	Duration of long power failures; in all three phases	3	0-0:96.7.15.255
EWG	Duration of long power failures; in phase L1	3	0-0:96.7.16.255
EWG	Duration of long power failures; in phase L2	3	0-0:96.7.17.255
EWG	Duration of long power failures; in phase L3	3	0-0:96.7.18.255
Electricity related objects - PQ- monitored values	Duration of last long power failure in any phase	3	0-0:96.7.19.255
Electricity related objects - PQ- monitored values	Time threshold for long power failure	3	0-0:96.7.20.255
EWG	Man. Spec. / Time for short power failure ph1	3	0-0:96.7.130.255
EWG	Man. Spec. / Time for short power failure ph2	3	0-0:96.7.132.255
EWG	Man. Spec. / Time for short power failure ph3	3	0-0:96.7.134.255

6. Tariff control

The meter allows energy consumption registration in up to four tariffs.

There is a possibility of either internal or external tariff control. Internal tariff control uses integrated real time clock (RTC). External tariff device is used for external tariff control.

In case of external tariff control is used, external tariff device signal output is connected on the meter's auxiliary terminal labelled 51. In that case 2 tariff system is applied.

On the other hand, 4 tariff system needs one more signal output from external tariff device to be connected on the meter's auxiliary terminal labelled 52.

Selection of tariffs, using external tariff inputs, is done in the following scheme:

Table 6.1. *Four tariff system external control scheme*

	51	52
T1	0	0
T2	230 V	0
T3	0	230 V
T4	230 V	230 V

In case of using internal switch for tariff control a more complex structure involving time-of-use tariffs (TOU) shall be implemented for tariff register management:

- 4 seasons
- 4 week types
- 5 different days in a week
- 8 transition daily
- 10 different holydays

The active tariff is determined according to the tariff schedule and indicated by a flashing cursor on the display. The tariff schedule is determined by the energy supplier. On delivery, meters are initialized with agreed tariff system that suits the application of energy supplier. Changes in tariff system are made by using internal or external communication (hand-held terminal, PC, etc.) with appropriate software. All tariff system changes are password protected.

Table 6.2. *Tariff objects*

Type	Object / Attr	Class Id	OBIS
Abstract objects - Time related issues	Activity Calendar	20	0-0:13.0.0.255
Abstract objects - Time related issues	Tariffication script table	9	0-0:10.0.100.255
Abstract objects - Time related issues	Special Days Table	11	0-0:11.0.0.255

7. Software update

The meters family EWGE32x and EWGE34x support firmware update.

The meter stores information about actual firmware version, as well as firmware versions of communication modem and in-home display devices (HAN) if any.

Table 7.1. *Firmware objects*

Type	Object / Attribute	Class Id	OBIS
Abstract objects - Firmware Upgrade	Active firmware version	1	1-0:0.2.0.255
Abstract objects - Firmware Upgrade	Active firmware version signature	1	1-0:0.2.8.255
Abstract objects - Firmware Upgrade	Active firmware version 1	1	1-1:0.2.0.255
Abstract objects - Firmware Upgrade	Active firmware version signature 1	1	1-1:0.2.8.255
Abstract objects - Firmware Upgrade	Active firmware version 2	1	1-2:0.2.0.255
Abstract objects - Firmware Upgrade	Active firmware version signature 2	1	1-2:0.2.8.255
Abstract objects - Firmware Upgrade	Image transfer activation scheduler	22	0-0:15.0.2.255
Abstract objects - Firmware Upgrade	Image transfer activation scheduler	22	0-0:15.0.2.255
EWG	Image activation scheduler - Application	22	0-1:15.0.2.255
EWG	Image activation - Application	9	0-1:10.0.107.255
Abstract objects - Firmware Upgrade	Predefined Scripts - Image activation	9	0-0:10.0.107.255

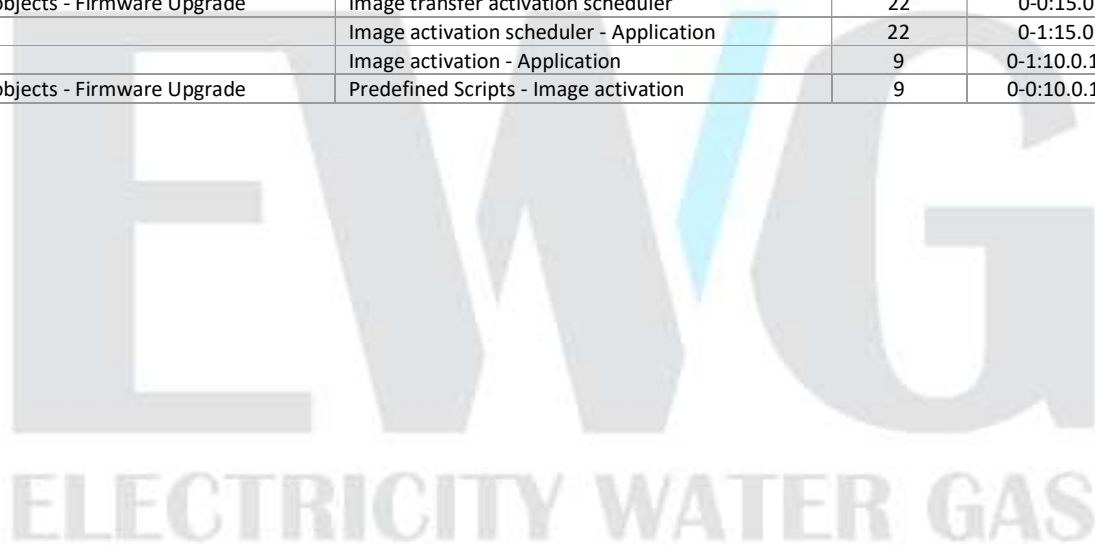

8. Data transfer security

The meter supports three levels of data transfer security. Each type of the meter's data can be addressed to different association with different security level.

- not protected
- low level of security - passwords
- high level of security – ciphering

Ciphering - a symmetric key algorithm AES-GCM128 has been selected, as specified in NISTSP 800-38-D. It provides authenticated encryption to xDLMS APDUs.

For key transport, the AES key wrap algorithm has been selected.

Table 8.1. *Data transfer security objects*

Type	Object / Attribute	Class Id	OBIS
Abstract objects - Association & Security	Security - Receive frame counter - unicast key	1	0-0:43.1.0.255
Abstract objects - Association & Security	Security - Receive frame counter - broadcast key	1	0-0:43.1.1.255
EWG	Invocation counter Local Management	1	0-0:43.1.2.255
EWG	Invocation counter Local Reading	1	0-0:43.1.3.255
EWG	Invocation counter Local Pairing	1	0-0:43.1.4.255
Abstract objects - Association & Security	Current association	15	0-0:40.0.0.255
Abstract objects - Association & Security	SAP Assignment	17	0-0:41.0.0.255
Abstract objects - Association & Security	Security setup	64	0-0:43.0.0.255
EWG	Security setup Local Management	64	0-0:43.0.2.255
EWG	Security setup Local Reading	64	0-0:43.0.3.255
EWG	Security setup Local Pairing	64	0-0:43.0.4.255

ELECTRICITY WATER GAS

9. Meter marking

Label	Description	Meter label						
		no. of phases	connection	direction	current	class active	class reactive	switch
		E3	1	1	N3	AB (A10)	R20	S
Number of measurement systems	one measurement system	E1						
	two measurement systems	E2						
	three measurement systems	E3						
Connection	direct connection		1					
	current transformer		2					
	voltage transformer		3					
	current and voltage transformers		4					
Energy direction	total active energy A			1				
	import/export active energy A+/A-			2				
Nominal (maximal) current	5(40) A				N1			
	5(60) A				N2			
	5(80) A				N3			
	10(40) A				N4			
	10(60) A				N5			
	10(80) A				N6			
	5(6) A				N7			
	5(10) A				N8			
	5(100) A				N9			
	10(100) A				N10			
Active energy accuracy class	0.2S					A02S		
	0.5S					AC (A05S)		
	1					AB (A10)		
	2					AA (A20)		
Reactive energy accuracy class	2						R20	
	3						R30	
Switch	No switch							-
	Internal switch (integrated)							S

10. Packaging and Storage

The meter package implies a plastic bag with the warranty card enclosed. Transport package contains 12 pcs, each followed by the respective warranty card and instructions for handling and installation. Bulk package is accompanied with a packing list containing serial numbers of the meters, meter type and manufacturers' labels.

